

ME 110: Hexapod Final Report

Bianca Yang, Max Wang

June 2019

I. Project Description

The objective of this project was to deepen our understanding and experience in robotics systems by building a hexapod. We were responsible to manufacturing components to fit together 18 HEBI actuators and for writing the software in a ROS framework to control the robot. Our results and process are discussed in the following sections: architecture and design, results and discussion, future work, and conclusion and acknowledgements.

II. Architecture and Design

The hexapod was manufactured out of 3003 aluminum, 3'x2'x1/4"; 6061 aluminum, 3'x2'x1/2"; and six 3003 aluminum tubes, 1.5" OD, 1' length. The semicircular feet were 3D printed with copper - PLA filament. The robot body is 400 mm x900 mm (15.7 in x 35.4 in) and stands at a max height of approximately 10in. Manufacturing was completed in the Jim Hall Shop in the basement of Spalding.

Figure 1 shows the fully assembled CAD of the bot. Additional figures can be seen in the Appendix A.

The robot was programmed in C++ using the ROS framework. The basic node architecture for the system can be seen in Figure 2. The brain node is responsible for generating trajectories and sending points that make up each trajectory (stand, tripod walk, etc.) to the control node. The control node is responsible for sending these points to the gait node and transforming these points to account for error. For example, the control node will increase

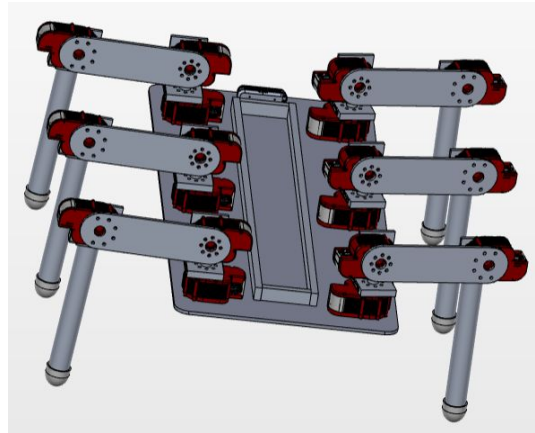
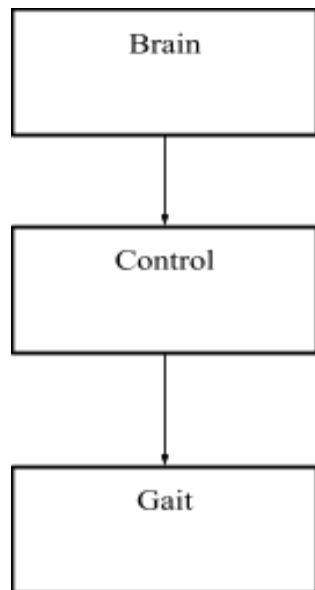

Figure 1. Hexapod CAD.



effort (torque) commanded to the gait node if there is any deviation in position. The control node “pulls” points from the brain node. The gait node is responsible for sending corrected instructions from control to the actuators. The control and brain nodes receive feedback (position, velocity, effort) from the actuators.

Code is available on Github under branch “bianca”:

<https://github.com/mhwang55/me110/tree/bianca>

Figure 2. ROS Node Architecture.

III. Results and Discussion

The results can be most clearly seen in this YouTube video we compiled:

https://www.youtube.com/watch?v=icu85y6lr8&fbclid=IwAR12SFRf56N2YyojY5wSfUAfvzm8P_OiC7cYuu9a7VHjBT0AzN7SK3DBqsQ

For more information on our expected results, please see our initial proposal, which is appended to this document.

It is clear from Table 1 below that we were not able to accomplish nearly as much as we had expected to. Some of the reasons for this are: manufacturing took much longer than expected, standing was more unstable than expected and required a code re-architecture to include a control loop, and tripod gait proved to be unusable due to torque limits on the motors. What we accomplished instead of the tripod gait was a 2-2-2 gait. In this case, the front left leg and the back right leg move together, then the middle two legs move together, then the front right leg and the back left leg move together. We were not able to continue working on the robot itself because one of the actuators failed during testing of the 2-2-2 gait. You can see this failure in the YouTube video.

Table 1. Expectations vs. Reality

	What We Originally Proposed					
	Develop tripod gait and other gaits	Implement object detection so the RealSense can consistently detect a feature of a human target the robot will follow	Develop an algorithm where the hexapod will follow an object at a constant distance using depth information from the RealSense	Implement gesture recognition using the RealSense	Combine gesture recognition with constant distance following	(Stretch goal) Implement stair climbing an obstacle avoidance
What We Were Able to Accomplish	We were not able to execute tripod gait due to torque limits, but we were able to develop a 2-2-2 gait.	We were not able to accomplish this objective.	We were not able to accomplish this objective.	We were not able to accomplish this objective.	We were not able to accomplish this objective.	We were not able to accomplish this objective.

IV. Future Work

We hope to be able to continue developing robotic systems as cool and intellectually challenging as this in the future. The future work on this robot includes most of the objectives that we were not able to execute upon: a more robust and accurate control system, optical flow for obstacle detection and avoidance, and target tracking and path planning.

V. Conclusion and Acknowledgements

We thank the robotics initiative and Aaron Ames and Eric Ambrose and Gunter Niemeyer for introducing us to the world of robotics and for supporting our efforts during this term and last. We have learned a significant amount about how to design for practical limits on motors and other components of the robot and how to manage real-world complications related to control of the robot and its components. We would also like to thank Bruce Dominiguez and John van Deusen from the Jim Hall Design and Prototyping Lab for teaching us how to use the machines and manufacture our parts, as well as Paula Gaetos from the TechLab for letting us use the CraftBots to print out our feet. It has been a pleasure working on this project, and we hope to be able to continue developing interesting robots like this in the future.

Appendix A. Original Proposal

Proposal to Design and Construct A Hexapod which can Follow Human Targets through Diverse Terrains

Max Wang, Bianca Yang

Spring 2019

Introduction:

Robotics is an immensely interesting area of research that has repeatedly proven its value in expanding human motor capacity. We have seen great advances in robot capabilities, from robotic arms to warehouse pick and pack assistants to pack mules to humanoid “butlers”. Caltech’s initiative in robotics, from bipedal robots to autonomous fire fighting drones, to space exploration robots have been great contributions to the scientific community and society.

We propose the construction and design of a autonomous hexapod that implements vision based tracking and robust mechanics as a way to promote the exploration of robotics on campus. This project is particularly exciting because it will be the *first* Caltech hexapod. Details of the robot and its functionality are provided below. Our proposed budget and equipment list is provided on the last page.

We are requesting **\$1840.50** from the robot initiative to complete this project.

Hexapod Design and Functionality:

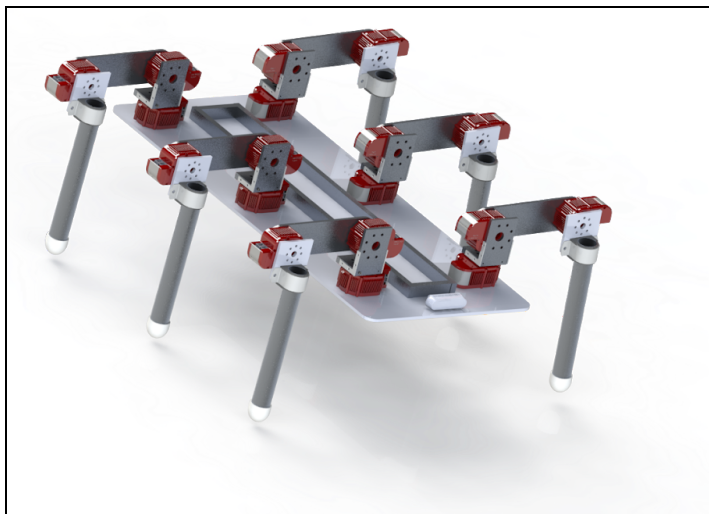

A rendering of the hexapod is shown in Figure 1.

The objective of the robot is to follow a human target around obstacles and diverse terrains and carry cargo for the human target. The inspiration for this design is the [Gita](#) mobile carrier from Piaggio. The Gita uses computer vision to track its target and has a 2000 cubic inch capacity.

Figure 1: Rendered model of hexapod

The hexapod is actuated with 18 [HEBI](#) actuators, three for each leg. Rotation axes for the legs can be seen in Figure 2.

On startup, the hexapod will move into its standby position, where it is partially raised off the ground, and wait for commands from a human target. A human target can activate the hexapod's tracking function by closing its fist within the depth camera's field of view. The hexapod will attempt to follow the human across all hard-surface terrains around all environments, all while maintaining a set distance from the human. The hexapod should also be able to distinguish its target from other humans.

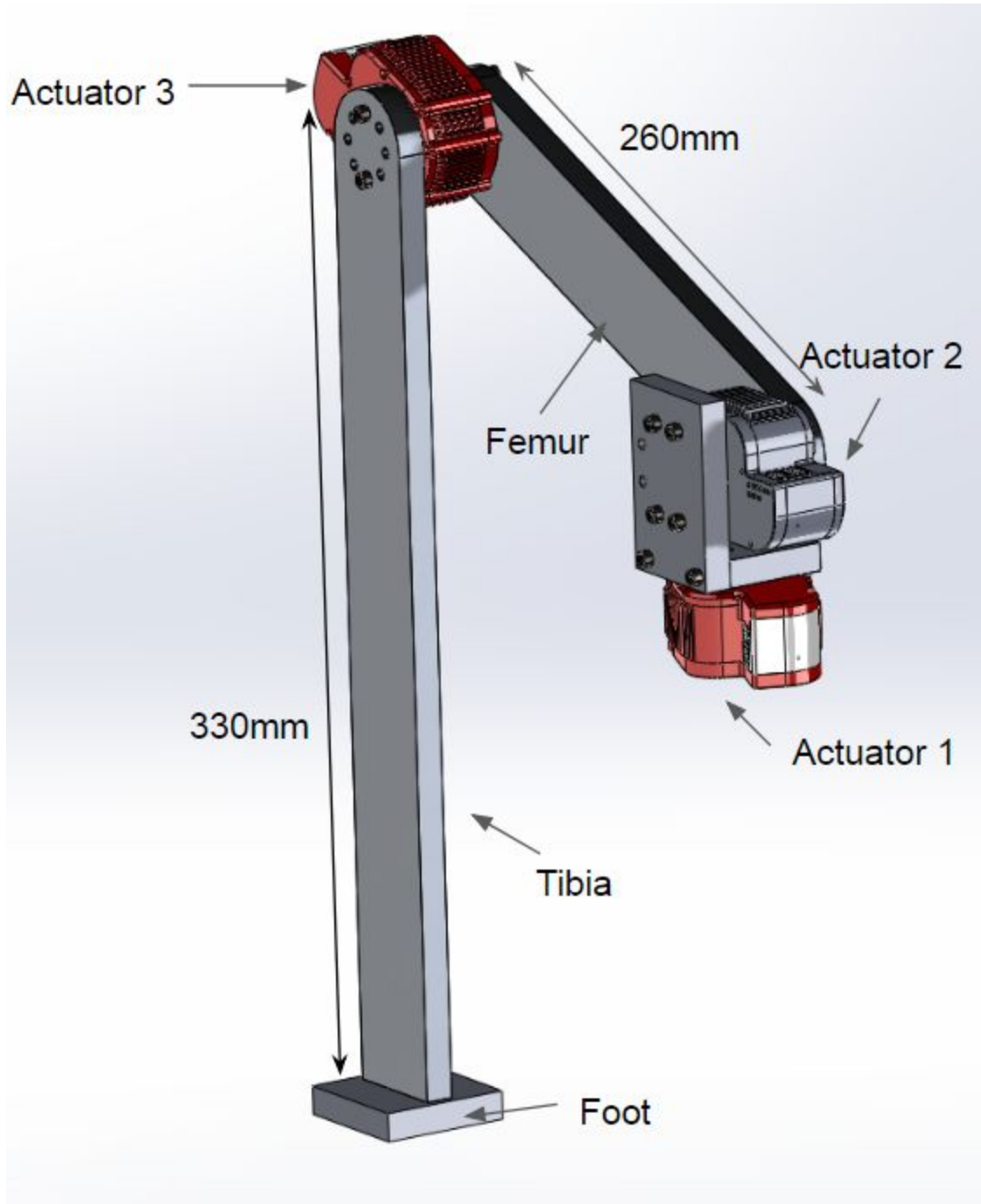

Figure 2: Leg coordinate system

If the hexapod loses track of its target, it will stop moving. The robot will either resume tracking once the target comes back into the field of view or switch targets when another human closes its fist in its field of view. If the original target closes its fist in front of the hexapod, the hexapod will stop tracking it and will return to its standby position.

We propose to use an [Intel RealSense D435](#) camera as the detector. The Intel RealSense is an infrared depth camera combined with a color camera. One way to implement human tracking is to use computer vision techniques like histogram of oriented gradients to detect the human and epipolar geometry to efficiently find and track a human target. Another strategy is to implement visual SLAM matching between a camera on the robot and a camera on the human.

A stretch goal is to have the robot climb stairs. This task requires more careful planning to ensure the robot's balance is maintained. If we are able to program the robot to conquer stairs, then we will have taught the robot to conquer all hard surfaces!

Advisors:

We plan to have Aaron Ames as our faculty advisor and Eric Ambrose as our graduate student advisor. We have received agreement from both to supervise our efforts to explore and promote robotics.

Bill of Materials:

18 [HEBI actuators](#) (expect to be provided by 134) ~ \$0
1 [Intel RealSense D435 camera](#) (expect to be provided by 134) ~ \$0
16"x36" 1/4" [aluminum plate](#) (for body) ~ \$49
27"x27" 1/4" [aluminum plate](#) (upper legs, and 1st piece of joint plate) ~ \$58
3"x2' 1/2" [aluminum sheet](#) (for 2nd piece of joint plate) ~ \$30
6x [Vibration-Damping Routing Clamp](#) ~ \$18
12' [aluminum tubing](#) ~ \$50
12"x24" x 1/2" [aluminum plating](#) (for rails) ~ \$86
12x [L-Brackets](#) ~ \$12
260x [M5x10](#) ~ \$31
12x [M5x8](#) ~ \$7
60x [M3x10](#) ~ \$8
1x [1/4-20 1in](#) ~ \$7
5x [XT90 splitter](#) ~ \$60 (includes shipping)
8s [lipo battery](#) ~ \$150
8s [lipo charger](#) ~ \$100
1x [8-port ethernet switch](#) \$25
1x [3.3ft USB C cable](#) ~ \$5.50
1x [Raspberry Pi 3](#) (expect to be provided by 134) ~ \$0
~10hrs [personal machining](#) \$100
~10hrs [shop machining](#) \$450
Shipping ~ \$400
Tax ~ \$200
Total: \$1846.50